

## Using ecoBright® T5 Adaptor (*Save It Easy*®) in multi-lamp fittings using 600mm lamps and switch-start Ballasts

### Application

This Product Technical Bulletin (PTB) applies to the retrofit installation of the ecoBright® T5 Adaptor *Save It Easy*®, into luminaires fitted with two, three or four, 600mm T8 or T12 lamps powered by two electromagnetic ballasts.

**SAFETY FIRST:** All recommended wiring work in this bulletin must only be completed by a qualified electrician.

### Installation Process

The existing lighting system may use either one or two ballasts. The wiring arrangement for a two ballast system is shown below. Each ballast circuit is treated separately, so in the event the fitting is a twin tube unit with one ballast,

apply the procedure accordingly.

1. To convert the fitting, remove the link wires (shown as dotted red lines in Figure 1.).
2. The links should be replaced by direct live or neutral feeds as appropriate to the lamp ends from the link wires have been removed as shown in Figure 1.
3. Any power factor capacitor fitted within the circuit should be removed and ensure the Save It Easy green starters have been fitted.
4. Refit any parts of the luminaire that were removed to gain access to the wiring.

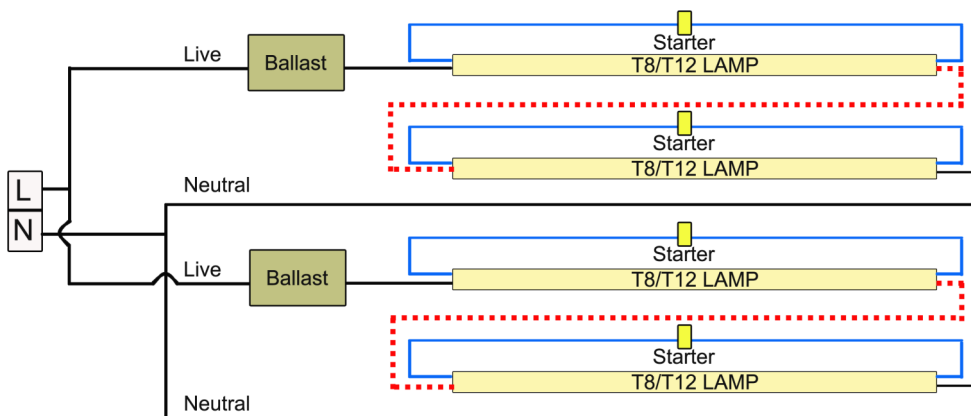

**Figure 1.** Original circuit diagram with link wires shown in red dotted lines. Blue lines represent starter circuits.

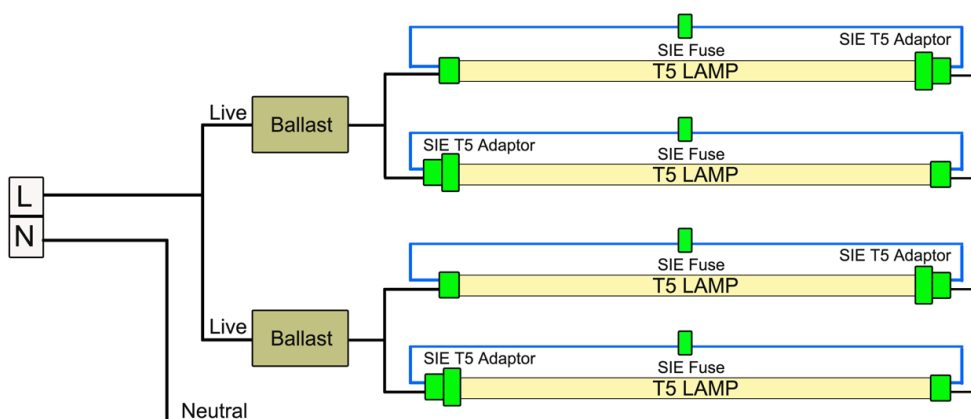

**Figure 2.** Modified Circuit diagram. Blue lines represent starter circuits.

### Contact us at:

ecoBright® Pty Ltd REC19870  
Office 15, 207-211A Buckley Street  
Essendon VIC 3040 Australia  
T 1800 133 666 F +61 3 9331 0028

ecoBright® energy solutions Limited  
Unit 16, 6 Airborne Road  
Albany NSC 0632 New Zealand  
T +64 9 415 7345 F + 64 9 415 7346

**DISCLAIMER:** The information contained herein is drawn from various sources and is understood to be correct at the time of publication. The information may not be free from errors or may be inappropriate for a specific application. ecoBright® accepts no liability whatsoever, to any person for any injury, loss or damage that may arise in connection with any use or reliance on the information. Please contact ecoBright® staff to discuss your specific application.